

A

Seminar report

On

Cellonics Technology

Submitted in partial fulfillment of the requirement for the award of degree
Of MCA

SUBMITTED TO:

www.studymafia.org

SUBMITTED BY:

www.studymafia.org

www.studymafia.org

Acknowledgement

I would like to thank respected Mr..... and Mr.for giving me such a wonderful opportunity to expand my knowledge for my own branch and giving me guidelines to present a seminar report. It helped me a lot to realize of what we study for.

Secondly, I would like to thank my parents who patiently helped me as i went through my work and helped to modify and eliminate some of the irrelevant or un-necessary stuffs.

Thirdly, I would like to thank my friends who helped me to make my work more organized and well-stacked till the end.

Next, I would thank Microsoft for developing such a wonderful tool like MS Word. It helped my work a lot to remain error-free.

Last but clearly not the least, I would thank The Almighty for giving me strength to complete my report on time.

www.studymafia.org

Preface

I have made this report file on the topic **Cellonics Technology**; I have tried my best to elucidate all the relevant detail to the topic to be included in the report. While in the beginning I have tried to give a general view about this topic.

My efforts and wholehearted co-corporation of each and everyone has ended on a successful note. I express my sincere gratitude towho assisting me throughout the preparation of this topic. I thank him for providing me the reinforcement, confidence and most importantly the track for the topic whenever I needed it.

www.studymafia.org

Content

- INTRODUCTION
- PRINCIPLE OF CELLONICS TECHNOLOGY
- CELLONICS CIRCUITS
- PERFORMANCE OF CELLONICS™ RECEIVER
- PROOF OF CONCEPT - DEMONSTRATION ON SYSTEMS
- CELLONICS ADVANTAGES
- CONCLUSION
- REFERENCE

www.studymafia.org

INTRODUCTION

Are you tired of slow modem connections? Cellonics Incorporated has developed new technology that may end this and other communications problems forever. The new modulation and demodulation technology is called Cellonics. I

n general, this technology will allow for modem speeds that are 1,000 times faster than our present modems. The development is based on the way biological cells communicate with each other and nonlinear dynamical systems (NDS). Major telcos, which are telecommunications companies, will benefit from the incredible speed, simplicity, and robustness of this new technology, as well as individual users.

In current technology, the ASCII uses a combination of ones and zeros to display a single letter of the alphabet (Cellonics, 2001). Then the data is sent over radio frequency cycle to its destination where it is then decoded. The original technology also utilizes carrier signals as a reference which uses hundreds of wave cycles before a decoder can decide on the bit value (Legard, 2001), whether the bit is a one or a zero, in order to translate that into a single character. The Cellonics technology came about after studying biological cell behaviour. The study showed that human cells respond to stimuli and generate waveforms that consist of a continuous line of pulses separated by periods of silence.

The Cellonics technology found a way to mimic these pulse signals and apply them to the communications industry (Legard, 2001). The Cellonics element accepts slow analog waveforms as input and in return produces predictable, fast pulse output, thus encoding digital information and sending it over communication channels.

Nonlinear Dynamical Systems (NDS) are the mathematical formulations required to simulate the cell responses and were used in building Cellonics. Because the technique is nonlinear, performance can exceed the norm, but at the same time, implementation is straightforward (Legard, 2001).

This technology will be most beneficial to businesses that do most of their work by remote and with the use of portable devices. The Cellonics technology will provide these devices with faster, better data for longer periods of time (Advantages, 2001). Cellonics also utilizes a few discrete components, most of which are bypassed or consume very little power.

This reduces the number of off the shelf components in portable devices while dramatically decreasing the power used, leading to a lower cost for the entire device. The non-portable devices of companies will benefit from the lack of components the machines have and the company will not have to worry so much about parts breaking.

www.studymafia.org

PRINCIPLE OF CELLONICS TECHNOLOGY

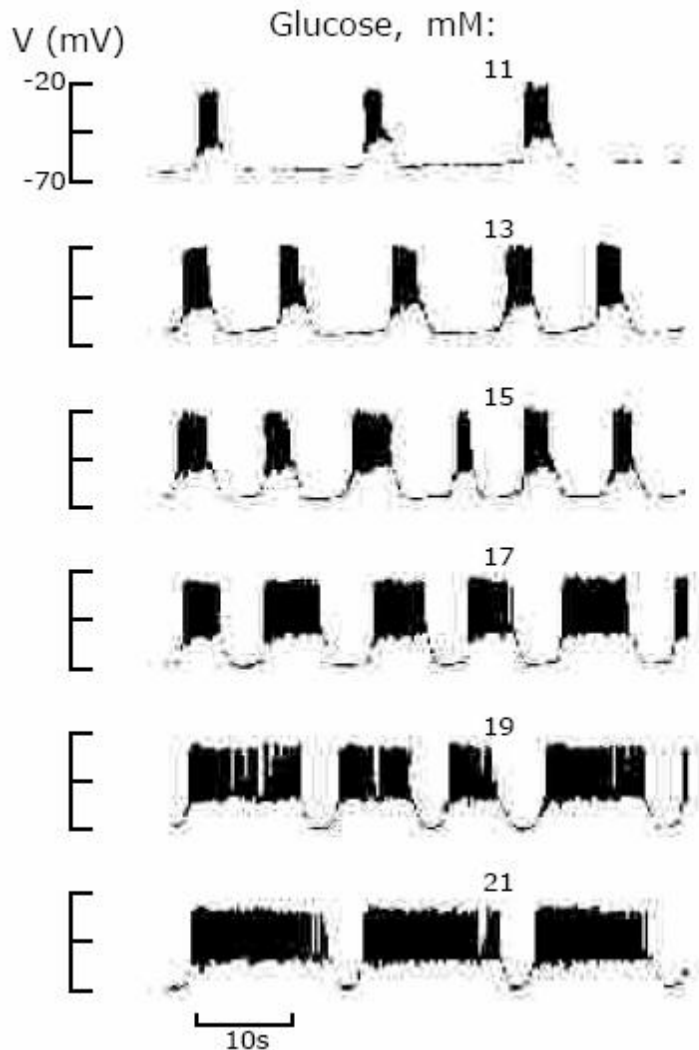

Measured β -cell Response

The Cellonics™ technology is a revolutionary and unconventional approach based on the theory of nonlinear dynamical systems (NDS) and modelled after biological cell behaviour¹. In essence, the term Cellonics is an euphemism for ‘electronic cells’. When used in the field of communications, the technology has the ability to encode, transmit and decode digital information powerfully over a variety of physical channels, be they cables or wirelessly through the air. There has been much research over the past decades to study inter-cell communications.

Laboratory studies have recorded electrical waveforms that show burst of spikes separated by periods of silence

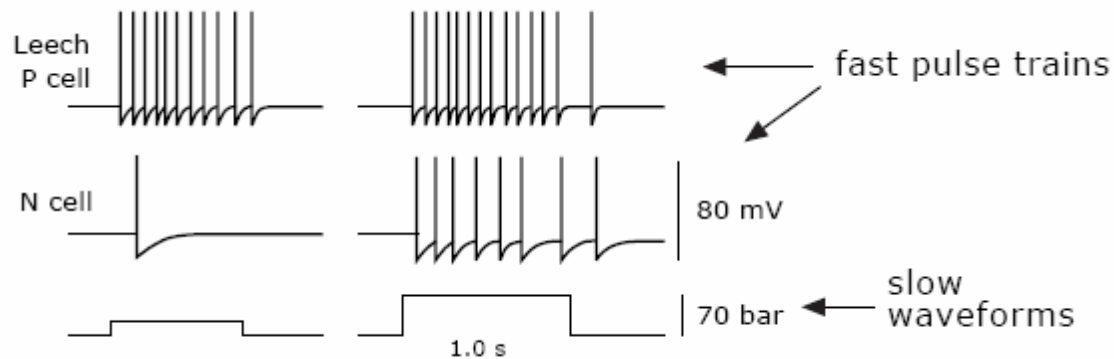

Waveforms

For examples, Fig 2a and Fig 2b show the behaviour of the β -cell and the Leech Nociceptor respectively. From these figures, we may observe that the slow waveforms² trigger the fast pulse trains³ allowing the cells to convey information (as postulated by some researchers). Note that while the fast pulse trains are always the same, the slow time-varying stimulus analog waveforms can take many arbitrary shapes. The number of the pulse trains varies according to the parameters of the slow analog waveforms. Thus, if a circuit can be found that accept an analog input waveform and output a set of pulse trains with predictable number of pulses in each burst, we have a very powerful means of encoding digital information and communicating it over a variety of physical channels. Cellonics Inc. has invented and patented a number of circuits that mimic the above biological cell behaviour. The Cellonics™ circuits are incredibly simple with advantages of low-cost, low power consumption and smallness of size. They can and have been used in various applications such as communications and electronic circuits (gated oscillator, sigma delta modulator, delta modulator, clock multipliers, etc). When applied in communications, the Cellonics™ technology is a fundamental modulation and demodulation technique. The Cellonics™ receivers are used as devices that generate pulses from the received analog signal and perform demodulation based on pulse counting and related algorithms.

1 The study of biological cell behaviour is ONLY an inspiration to the invention of Cellonics™ circuits. The Cellonics™ technology is NOT related to any neural network communications or neurophomic electronics.

2 Slow waveforms: Analogue waveforms that vary slowly with time. These waveforms can be in any arbitrary shape.

3 Fast waveforms/fast pulse trains: Waveform in the shape of pulses that varies rapidly with time.

CELLONICS CIRCUITS

Cellonics Inc. has developed and patented families of Cellonics™ circuits that are useful for various applications. One of these Cellonics™ circuits is an extremely simple circuit that exhibits the “Scurve” transfer characteristic. Fig 3a shows one of the possible circuit realizations. The circuit contains a negative impedance converter. Its I-V transfer characteristic is shown in Fig 3b. The transfer characteristic consists of three different regions. The two lines at the top and bottom have positive slope, $1/R_f$ and they represent the regions in which the Op-Amp is operating in the saturated (nonlinear) mode. In Fig 3b, the middle segment has a negative slope (negative resistance)

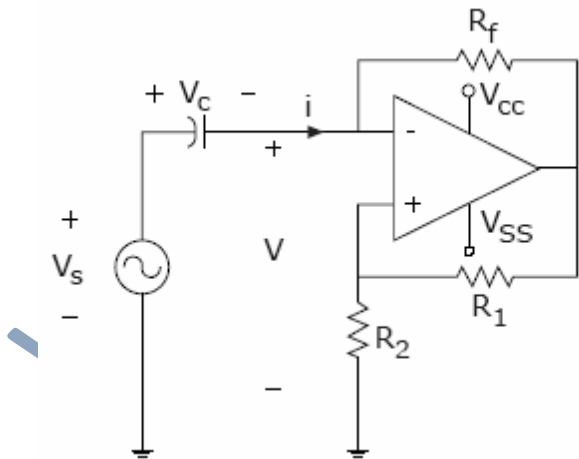

Cellonics Circuit

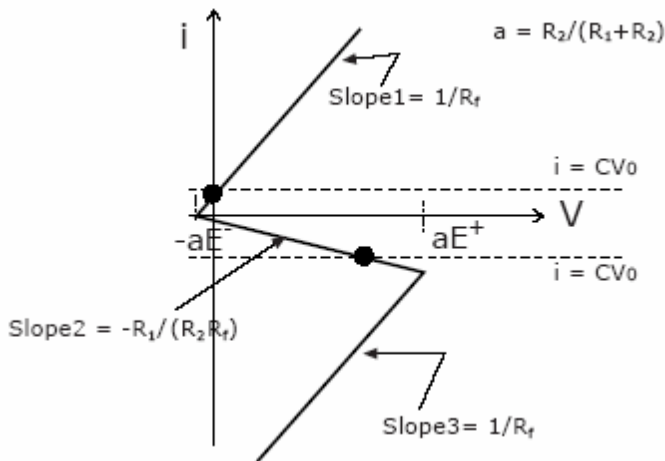

Phase Space & I-V Characteristics Curve

and represents the region in which the Op-Amp is operating linearly. It is this negative resistance region that allows the Op-Amp to oscillate and produce pulses bounded by the positive and negative saturation voltages.

$$V_s = V_c + V$$

$$\frac{dV}{dt} = \frac{dV_s}{dt} - \frac{i}{C}$$

$$\square -\frac{d}{i} = V - \psi(i)$$

For ease of explanation⁴, we assume that the input signal is a triangular waveform. Here we have $dV_s/dt = (V_0)$ depending on the slope of the triangular input waveform. Whenever the slope is positive, the Op-Amp is stable and outputs a constant saturation voltage. Thus a silent period is observed i.e. no spike is being produced. On the other hand, with properly selected circuit parameters whenever the slope of the triangular waveform is negative, the Op-Amp is unstable. In this region, the output is oscillating. The duration of each pulse is similar and the number of pulses generated depends on the length of time the slope remains negative. Thus by Controlling the duration of the negative slope, he number of pulses to be produced at the output of the Op-Amp can be controlled. The Cellonics™ circuit is robust against noise perturbations – as long as the effective negative slope keeps the Op-Amp unstable, the noise will not have an effect on the pulse generation. The level of tolerance against the noise perturbations is carried out by proper

selection of circuit parameters in the design. There are also many other families of Cellonics™ circuits. By using the Principle of Duality, the “N-curve” families of Cellonics™ circuits can be derived. In this case, the realization of the circuits can be based on the OP-AMP or devices such as the tunnel diode, etc. The transfer function of a tunnel diode exhibits the “N-curve” transfer characteristic inherently, which is a “dual” of the S-curve” family. By connecting an inductor and

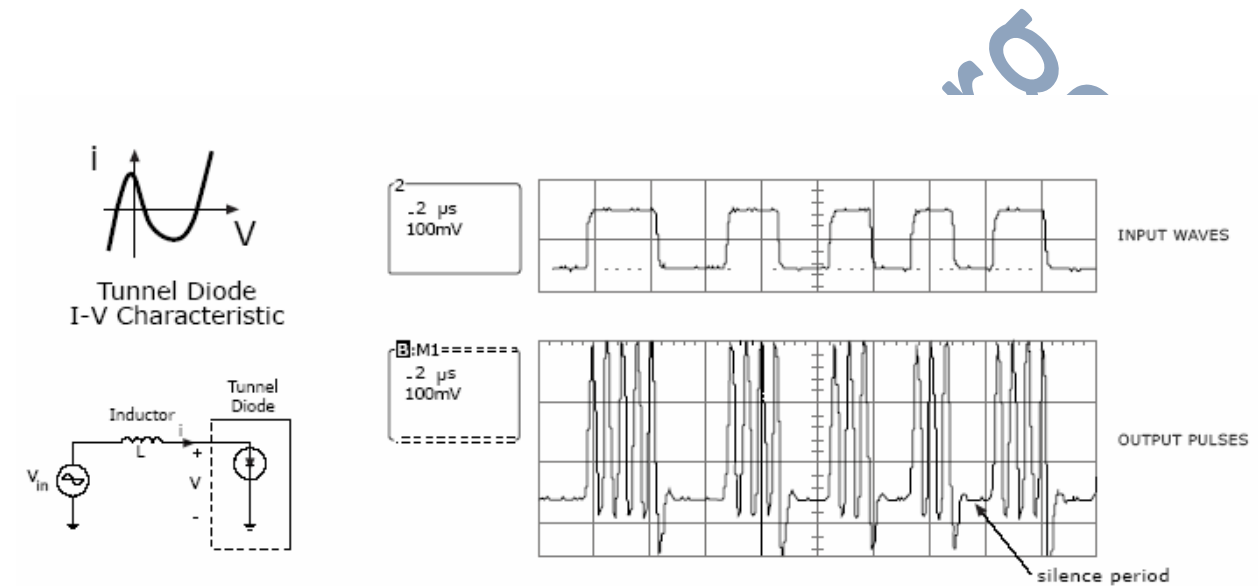

PN-Curve Cellonics™ Element

a tunnel diode in series, we can produce pulses that are separated by periods of silence. This family of circuits responds to the voltage level of the input signal. As an application example, a square wave signal is used in Fig 3c. In this case, the duration when the input signal is above a certain “threshold” voltage determines the duration that the circuit operates in the unstable region and consequently the number of pulses generated.

PERFORMANCE OF CELLONICS™ RECEIVER

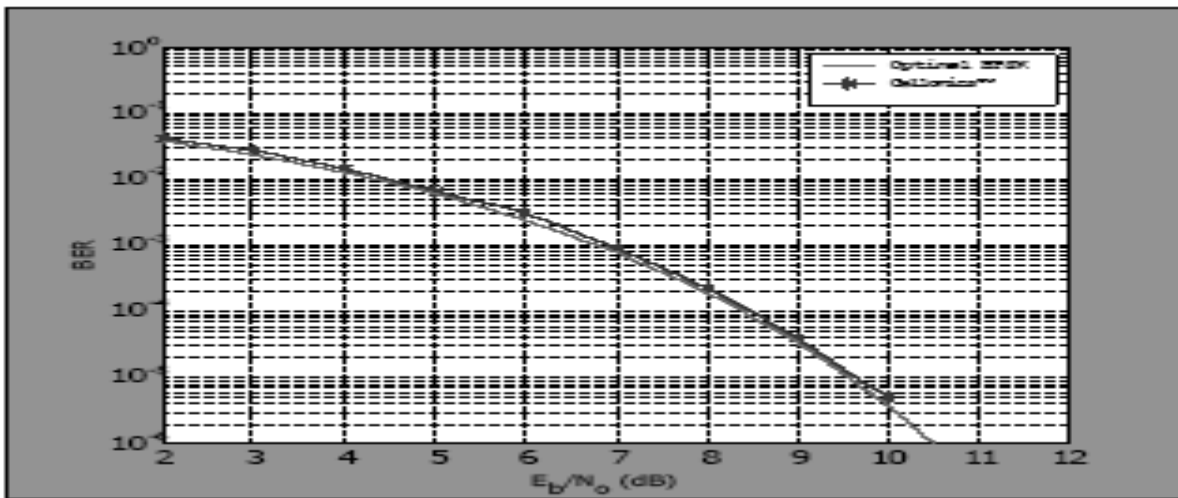

Cellonics™ Receiver Performance

BER Performance in a Narrowband Communication System

An important performance measure of any modulation scheme is its bit-error rate (BER) performance in a noisy channel. Fig 5a shows the numerical simulation results of the Cellonics™ receiver in the AWGN channel. Also shown in the figure is the theoretical curve of the optimal Binary Phase Shift Keying (BPSK) modulation scheme. From the figure, it is clear that the BER performance of the Cellonics™ modulation is able to match the theoretical optimal BPSK modulation scheme. This is achieved by using only 4 Cellonics™ elements which are very simple (please refer to Fig 3a and Fig 3d). Figure 5b shows another set of results in the multi-path environment which show that the Cellonics™

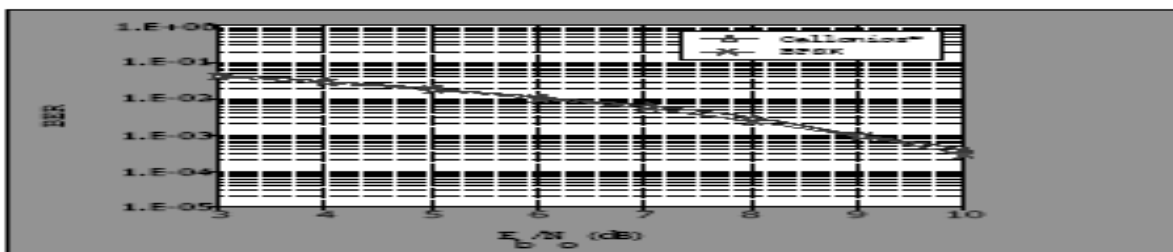

Performance in 2-path and AWGN Channel

receiver has similar performance as the BPSK receiver but with much simpler receiver architecture. Furthermore, in practical terms, the Cellonics™ receiver will have less implementation losses when compared to a conventional receiver.

BER Performance in an Ultra Wideband

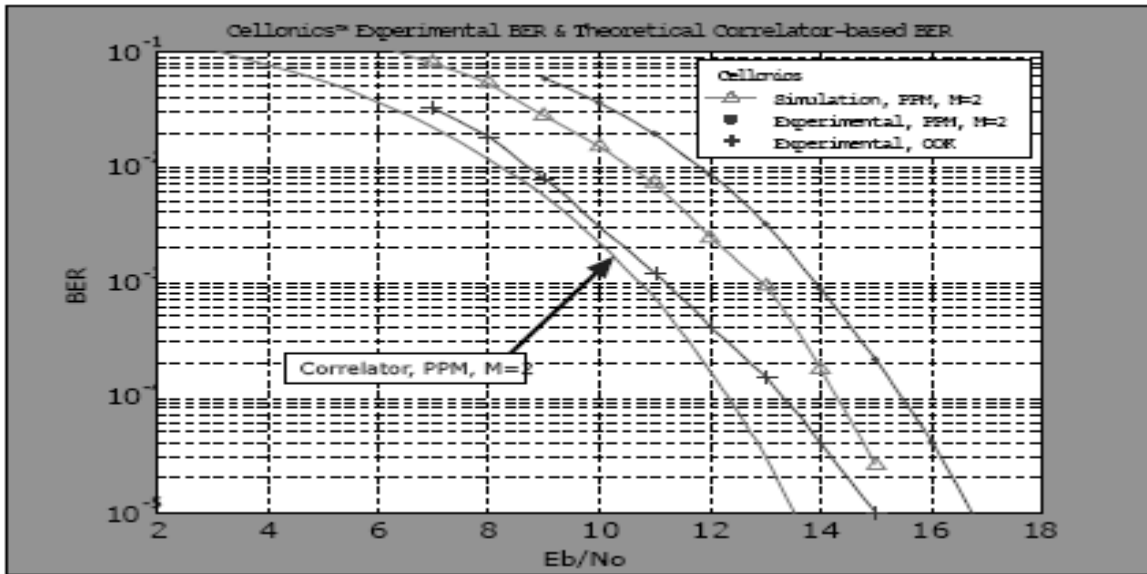

Performance in Cellonics™ UWB

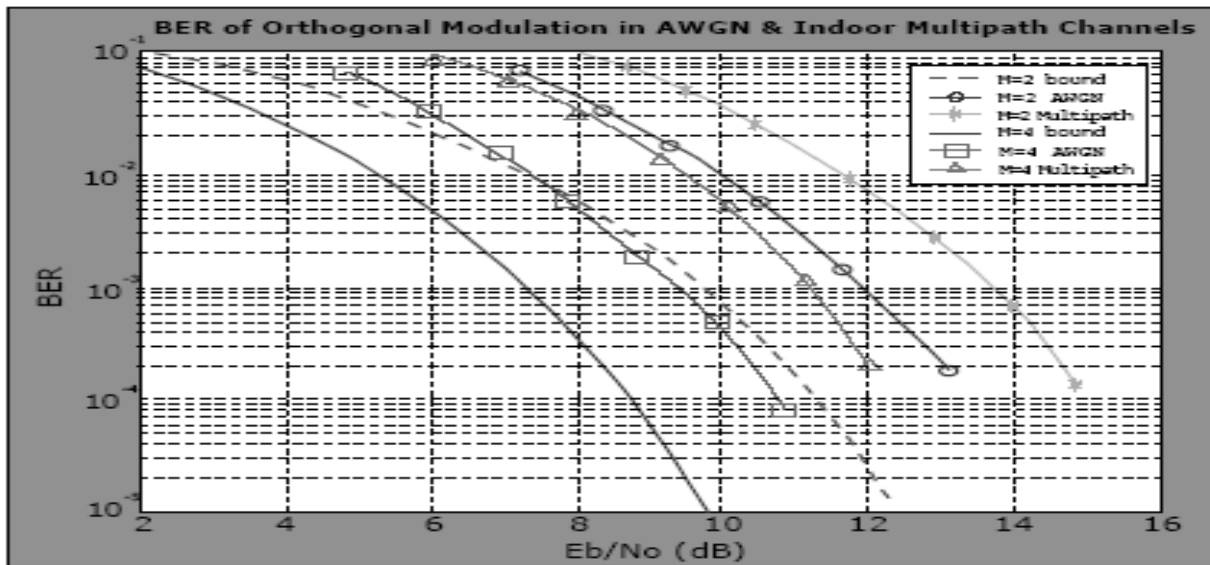

Performance in Cellonics™ UWB

UWB is a new radio system that occupies an ultra wide bandwidth. In UWB signaling, the transmission uses very short impulses of radio energy (less than a few nanoseconds in duration). This results in a spectrum that covers a wide range of radio frequencies. Consequently, the small amount of transmitted energy is spread over a wide frequency range resulting in very small energy per Hertz. It will cause little interference to the existing spectrum users. Typical correlator-based UWB receiver requires thousands of cycles and frames to acquire the signals and average out the noise.

The Cellonics™ technology can be used as a receiver to detect the UWB signals. The BER performance of the Cellonics™ UWB system has been evaluated in both simulation and experiment. Fig 4c shows the simulated and experimental results. Using the On-Off Keying method, the experimental Cellonics™ performance curve is less than 1 dB from the theoretical best performance using the correlate approach. However, the Cellonics™ UWB system has superior throughput and is potentially hundreds to thousands times faster as it uses only one to few frames (e.g. 7frames) to decode one information symbol depending on the power efficiency requirements. Fig 4d shows its performance in a dense in-door multipath environment. The fading margin is only 3 dB and indicates that it is suitable for indoor applications such as wireless local area networks.

PROOF OF CONCEPT - DEMONSTRATION ON SYSTEMS

In the following discussions, the parameters used in the demonstration systems such as the distance of transmission and the data rates are merely for ease of prototyping purposes and are NOT the limitation of the Cellonics™ technology.

Narrowband Communication System

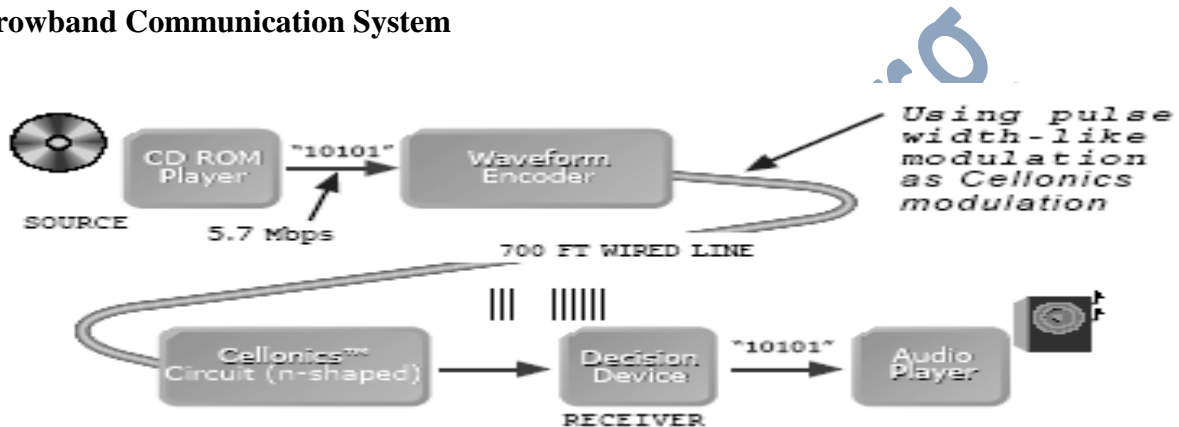

Wire line Cellonics™ Communication System (5.7 Mbps)

Fig 6a shows the block diagram of a proof-of concept demonstration system that transmits compact disc music at a data rate of 5.7 Mbps over a wired line. In this system, a CD-ROM player is used as a convenient signal source to provide the required bit stream. The digital data is modulated using a pulse width modulation scheme. These modulated data are then passed through a 700-ft telephone wire line. At the receiver, the data is demodulated using the “N-shaped” Cellonics™ circuit, which in this case uses only two elements - an inductor in series with a tunnel diode. To recover the digital information, the decision device simply counts the pulses to determine if it is a logic ‘1’ or ‘0’. The recovered data is then output to an audio player for real

time playback.

Note: This demo highlights good long distance performance.

Narrowband Communication System (Wireless)

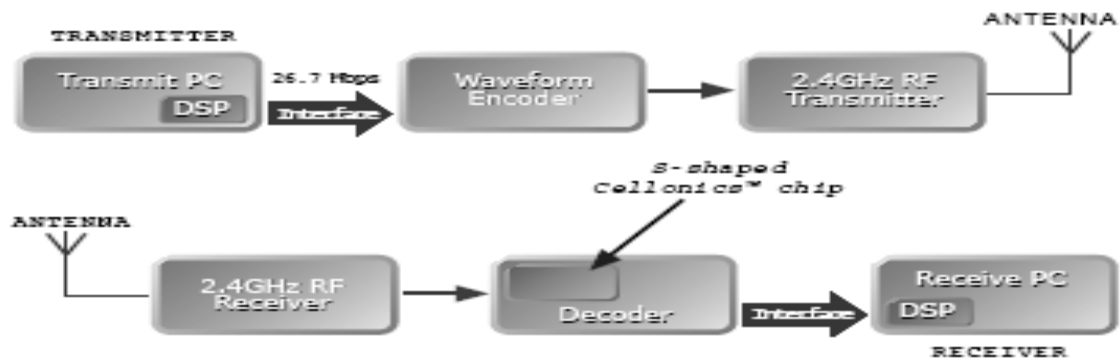

Wireless Cellonics™ Communication System

Fig 6b shows the block diagram of another demonstration system which is a 26.7 Mbps file transfer system. The system consists of a transmitter and receiver; both sub-systems further comprise three modules: the PC/DSP module, baseband transceiver module and the RF transmit/receive module. The DSP module resides in a personal computer and provides a high-speed data transmission interface with the transmit/receive PC. The DSP transmits a data file residing on the PC serially to the baseband transmitter at a data rate of 26.7 Mbps. The baseband transmitter converts these data from the DSP into FSK-like waveforms. The RF receiver module down converts the received signal using an AM envelope detector. The received waveform is fed into the “S-shaped” Cellonics™ chip to recover the data. The recovered data are sent to the DSP storage on the receiver PC. The transmission has no error correction scheme and the off-line BER check has zero error most of the time. The demonstration system shows a high throughput of data transfer and is 3 times faster as compared to a commercial Radio LAN product. Note: This demo highlights better than current wireless LAN (11 Mbps) performance.

Ultra Wideband Audio System

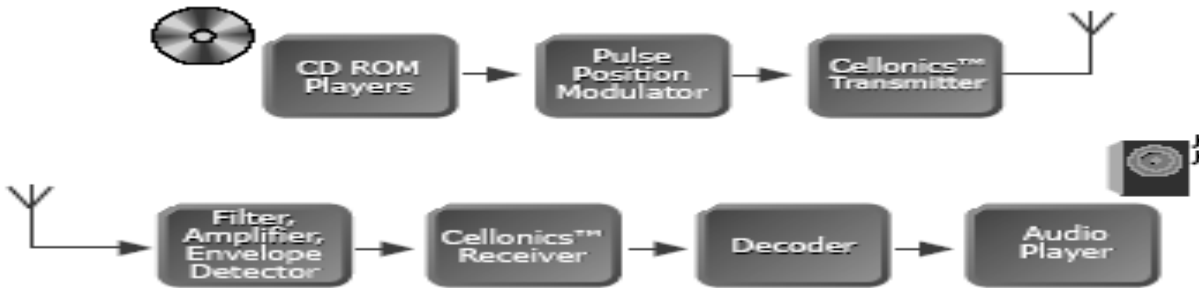

Cellonics™ UWB Wireless Audio Radio System

Fig 6c shows the block diagram of a UWB radio system. This system demonstrates the live transmission of compact disc music using UWB wireless technology. Digital data from two CD-ROM players is tapped at a rate of 11.4 Mbps. This data stream is fed into a UWB pulse generator and transmitted wirelessly. At the receiver end, the signal is detected and then fed to a Cellonics™ receiver to decode and the original music data is recovered/sent to an audio player for real-time playback.

Note: This demo highlights future application and good noise immunity.

Ultra Wideband Video System

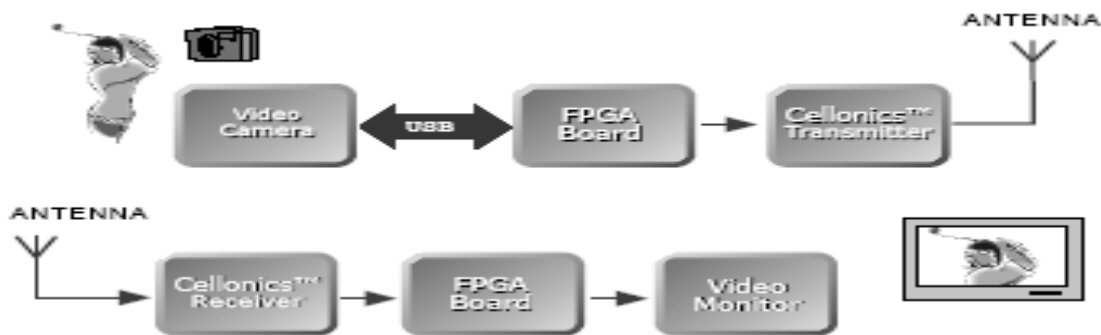

Cellonics™ UWB Wireless Video Radio System

Fig 6d shows the block diagram of a second UWB demonstration system that transmits real-time video images at a data rate of 12Mbps wirelessly to a video monitor. In this system, a simple web camera is used as the video capture source. The digital video information is fed into a pulse position modulation processing board (a Field Programmable Gate Array or FPGA board) via a USB connection before being frequency translated to a higher frequency band at a transmitter for sending over the air. The airborne signals are then detected by a UWB receiver and pulse

position demodulated back into digital video information for display at a video monitor. In both instances, an ultra simple Cellonics Transmitter and a simple Cellonics receiver are used. The speed of the system is only limited by the Video camera's USB interface data rate.

Note: This demo highlights the ultra simplicity, speed and robust performance of the Cellonics UWB transceiver technology in a popular consumer application.

CELLONICS ADVANTAGES

The impact of Cellonics™ is such that it effects a fundamental change in the way digital communications have traditionally been done. As such, many communication devices will benefit from its incredible simplicity, speed and robustness.

Devices built with the Cellonics™ technology will save on chip/PCB real estate, power and implementation time.

a. New Life to Communication Devices

The strength of the Cellonics™ technology lies in its inherent Carrier-rate Decoding™ (i.e. extremely fast decoding rate), multilevel capability (spectral efficiency), simple circuitry, low power consumption and low cost. Some telecommunication application examples in wireless communication are cellular networks(2/3/4 G and beyond), W-LAN/Home networks ,LMDS, broadcasting, military radio, RF identification tags, low cost radar with fine range precision and sensor for automobiles. In wire line communication, some areas where the Cellonics™ technology is deployable are: high-speed modem cable modem, xDSL), LAN/Home networks, backbone telephony/data networks, power line communications and military applications. Beyond its application in telecommunication, the Cellonics™ technology is also applicable in the electronics circuits such as gated oscillators, delta modulators, sigma-delta modulators and clock multipliers, etc.

b. Savings on Chip/ PCB Real Estate

Because of its simplicity, a receiver implemented with Cellonics™ can save as much as 4 times the chip real estate. (Comparison made with a zero-IF receiver designed with the same 0.8Mm BiCMOS process.)

c. Savings on Power

Using the same design and comparison above, it was found that a Cellonics™-based receiver consumed 3 times less power. This is possible because a Cellonics™ circuit is built with a few discrete components that are mostly passive and hence consume very little or negligible power. Cellonics™ returns a high 'power budget' back to a communication device. Designers can use this 'extra' power to 'finance' other power-needy features in a device such a color screen, GPS receiver, etc. Else, the device will simply end up having a longer battery life. (As in the case of mobile phones.)

	Cellonics Dual	Conventional Zero-IF Receiver
Chip area	1.12 mm ²	5 mm ²
Power consumption	50 mW	180 mW

d. Savings in Implementation Time

In a receiver, the Cellonics™ circuit replaces many traditional subsystems such as the amplifier, mixer, PLL, oscillator, filter, crystal quartz, etc. that are necessary in a common Super heterodyne and Super homodyne design. These parts in these subsystems can be costly, fragile and noisy. Aside from this, the subsystems need great expertise to be put together and fine-tuned. It is also difficult to miniaturize. With the simplicity and robustness of Cellonics™, implementation time is swift without the sacrifice on performance.

e. Build or Rejuvenate your Products with Cellonics™

The incredible simplicity, low cost, low power consumption of Cellonics™ makes it ideal for use in your next generation of feature-rich products that need to be small in size and long on power

reserve. Else, the technology is also ideal in giving your current products a new low- cost and power-saving receiver engine.

CONCLUSION

The Cellonics communication method is one inspired by how biological cells signal. It is a fresh and novel look at how digital signals may be conveyed. In this digital day and age, it is timely; current digital communication designs are mostly derived from old analog signal methods. With the Cellonics method, much of the sub-systems in a traditional communication system are not required. Noise-generating and power-consuming systems such as voltage-controlled oscillators, PLLs, mixers, power amplifiers, etc., are eliminated. To a communications engineer, this is unheard off. One just doesn't build a communication device without an oscillator, mixer, or....

Such is the revolutionary impact of Cellonics. Engineers will have to reform their thinking- that such a simple solution is possible.

REFERENCE

- www.google.com
- www.wikipedia.com
- www.studymafia.org

www.studymafia.org